

ΟΙΚΟΝΟΜΙΕΣ ΧΩΡΙΣ ΚΑΜΜΙΑ ΑΝΤΑΓΩΝΙΣΤΙΚΗ ΙΣΟΡΡΟΠΙΑ

Βασικές οικονομικές περιπτώσεις μη ύπαρξης ανταγωνιστικής ισορροπίας

- **μη κυρτες προτιμησεις η τεχνολογιες**

(Nonconvexities, indivisibilities, fixed costs, increasing returns to scale)

- **περιουσιες εκτος του εσωτερικου του εφικτου συνολου καταναλωσης**

(boundary endowments, poverty traps)

Θα βρουμε οτι,σε ολες τις περιπτωσεις,η μη υπαρξη συνισταται στο οτι σε καποια αγορα οι καμπυλες προσφορας-ζητησης θα ειναι της μορφης

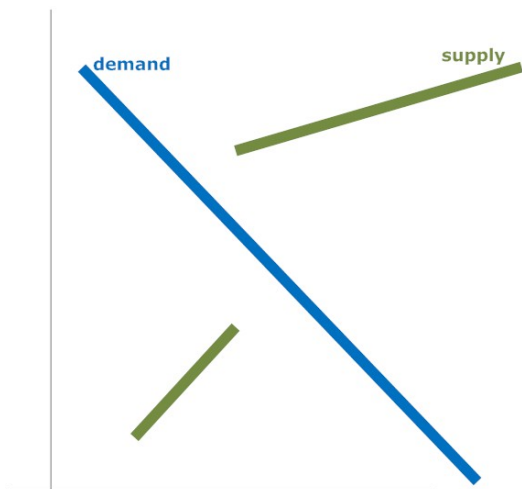
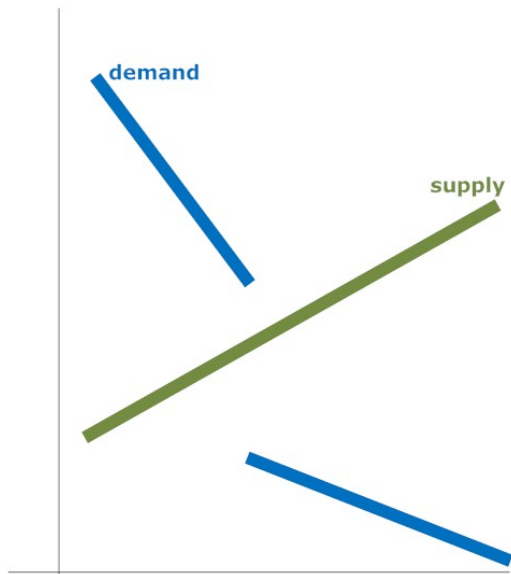

Τα χασματα οφείλονται στο γεγονός ότι οι λύσεις των σχετικών προβλημάτων μεγιστοποίησης δεν είναι συνεχείς συναρτήσεις των παραμετρών, ή στο ότι τα σύνολα των ολικών μεγιστών δεν είναι κυρτά, και όχι στην ασυνεχία των αρχικών δεδομένων (δηλαδή της τεχνολογίας και των προτιμήσεων).

NONCONVEXITIES

ΠΑΡΑΔΕΙΓΜΑ 1. FIXED COSTS

Θεωρούμε οικονομία με

- δυο καταναλωτες,τους 1 και 2
- δυο αγαθα,τα A, L
- μια επιχειρηση.

Το αγαθο A παραγεται απο το αγαθο L με την ΜΗ ΚΟΙΛΗ(αλλα οιονει κοιλη) συναρτηση παραγωγης

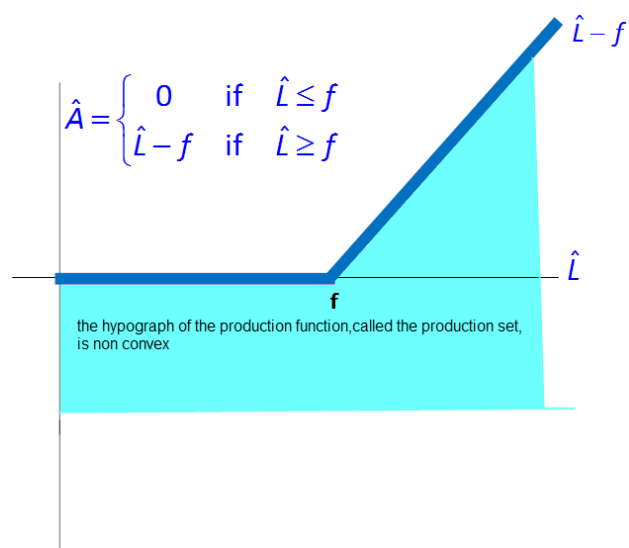

Η παραμετρος f ονομαζεται παγιο κοστος(fixed cost), και ικανοποιει $0 < f < \frac{1}{2}$. Παρατηρούμε οτι το μεσο προιον(average product)

$$\frac{\hat{A}}{\hat{L}} = \begin{cases} 0 & \text{if } \hat{L} \leq f \\ 1 - \frac{f}{\hat{L}} & \text{if } \hat{L} \geq f \end{cases}$$

ειναι αυξουσα συναρτηση της εισροης , και δεν εχει μεγαστο

increasing average product

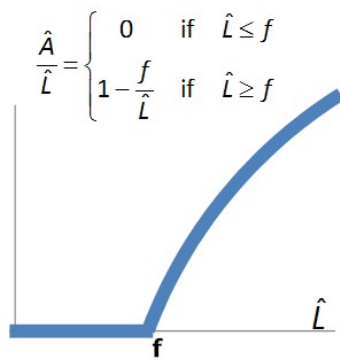

Ο καταναλωτής 1

- έχει μια μονάδα του αγαθού L
- έχει προτιμήσεις της μορφής $U_1 = A_1 - \frac{1}{2}L_1^2$

Ο καταναλωτής 2

- είναι ο μοναδικός ιδιοκτήτης της επιχείρησης.
- έχει προτιμήσεις της μορφής $U_2 = A_2$

ΥΠΟΛΟΓΙΣΜΟΣ ΑΝΤΑΓΩΝΙΣΤΙΚΗΣ ΙΣΟΡΡΟΠΙΑΣ ΜΕ ΜΕΤΑΒΙΒΑΣΕΙΣ

ονομαζω την τιμή του κάθε αγαθού

p = price of A , w = price of L

τυποποιώ τις τιμές (προαιρετικά)

$p = 1$

Ορίζω το εισόδημα του κάθε καταναλωτή

$$M_1 = wL_1 + T_1, M_2 = \Pi + T_2, T_1 + T_2 = 0 \quad (1)$$

λύνω το πρόβλημα μεγιστοποίησης του κάθε καταναλωτή

$$\max_{L_1, A_1} U_1 = A_1 - \frac{1}{2}L_1^2 \text{ subject to } 0 \leq A_1 \leq M_1 = wL_1 + T_1, 0 \leq L_1 \leq 1$$

$$\max_{A_2} U_2 = A_2 \text{ subject to } 0 \leq A_2 \leq M_2 = \Pi + T_2$$

Οι λύσεις των προβλημάτων αυτών είναι οι συναρτήσεις προσφοράς-ζήτησης του κάθε καταναλωτή

$$L_1 = \begin{cases} w & \text{if } w \leq 1 \\ 1 & \text{if } w \geq 1 \end{cases}, A_1 = \begin{cases} w^2 + T_1 & \text{if } w \leq 1 \\ w + T_1 & \text{if } w \geq 1 \end{cases} \quad (2)$$

Labor supply function

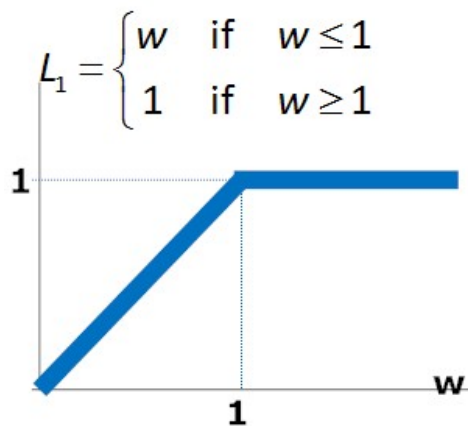

$$A_2 = \Pi \quad (3)$$

λυνω το πρόβλημα μεγιστοποίησης της καθε επιχείρησης

$$\max_{\hat{L}} \Pi = \text{revenue-cost} = p\hat{A} - w\hat{L} = \begin{cases} -w\hat{L} & \text{if } \hat{L} \leq f \\ (1-w)\hat{L} - f & \text{if } \hat{L} \geq f \end{cases}$$

Οι λύσεις των προβλημάτων αυτών είναι οι συναρτήσεις προσφοράς-ζήτησης της καθε επιχείρησης (για λεπτομερή εξαγωγή της λύσης δες το παράδειγμα 5 της διαλέξης για τη μεγιστοποίηση)

$$(\hat{L}, \hat{A}, \Pi) = \begin{cases} (\infty, \infty, \infty) & \text{if } w < 1 \\ (0, 0, 0) & \text{if } w \geq 1 \end{cases} \quad (4)$$

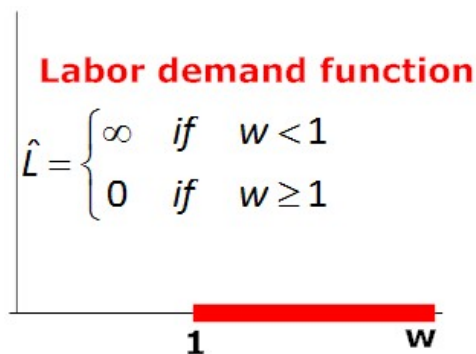

λυνω τις συνθήκες ισορροπίας

demand	=	supply	
$A_1 + A_2$	=	\hat{A}	(5)
\hat{L}	=	L_1	

Απο τις (4),(2) παρατηρούμε ότι το σύστημα (5) δεν έχει καμία λύση

nonexistence of competitive equilibrium

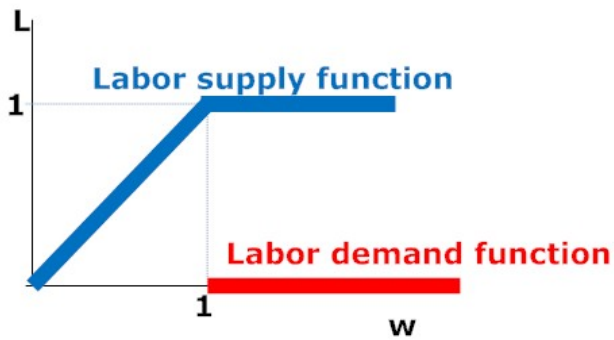

Σημείωση Ενώ στο παραδειγμα ανταγωνιστικες ισορροπιες με μεταβιβασεις δεν υπαρχουν, τα σημεια παρετο ειναι $L_1 = 1, A_1 + A_2 = 1 - f$. Αρα δεν ισχυει το δευτερο θεωρημα της ευημεριας

ΠΑΡΑΔΕΙΓΜΑ 2. MINIMUM EFFICIENT SCALE

Θεωρουμε οικονομια με

- ενα καταναλωτη.
- Δυο αγαθα, τα A και X
- μια επιχειρηση.

Το αγαθο A παραγεται απο το αγαθο X με την ΜΗ ΚΟΙΛΗ(αλλα οιονει-κοιλη) συναρτηση παραγωγης

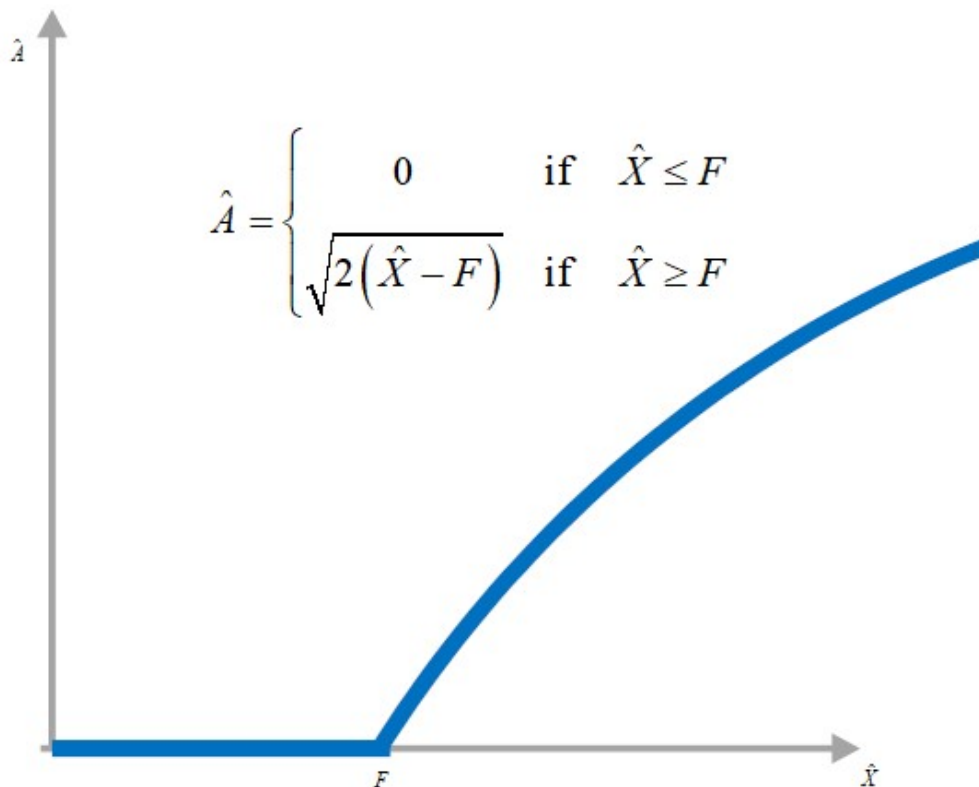

οπου το F είναι μια θετική παραμετρος. Παρατηρούμε οτι το μεσο κοστος

$$\frac{\hat{X}}{\hat{A}} = \begin{cases} 0 & \text{if } \hat{A} = 0 \\ F + \frac{\hat{A}^2}{2\hat{A}} & \text{if } \hat{A} > 0 \end{cases}$$

ελαχιστοποιείται στο σημείο $\hat{A} = \sqrt{2F}$, το οποίο και ονομάζεται ελάχιστη αποτελεσματική κλιμακα παραγωγής (minimum efficient scale of production).

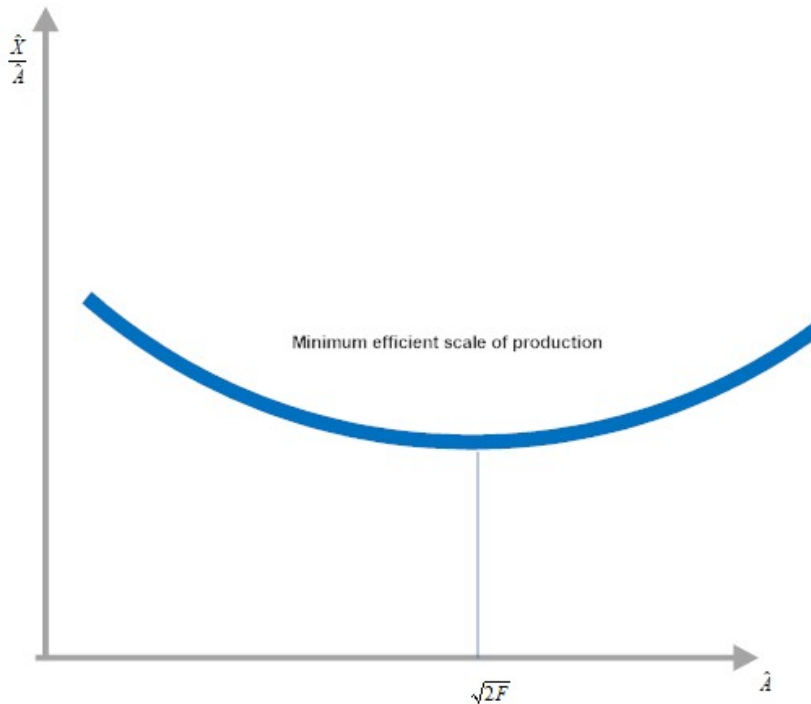

Ο καταναλωτης

- έχει $\bar{X} > F$ μοναδες του αγαθου X
- είναι ο μοναδικος ιδιοκτητης της επιχειρησης.
- έχει προτιμησης της μορφης

$$u = \alpha \log A + (1 - \alpha) \log X \quad (1)$$

οπου το α είναι παραμετρος, $0 < \alpha < 1$.

ΥΠΟΛΟΓΙΣΜΟΣ ΑΝΤΑΓΩΝΙΣΤΙΚΗΣ ΙΣΟΡΡΟΠΙΑΣ

ονομαζω την τιμη του καθε αγαθου

$p = \text{price of } A, w = \text{price of } X$

Οριζω το εισοδημα του καθε καταναλωτη

$$M = w\bar{X} + \Pi \quad (2)$$

λυνω το προβλημα μεγιστοποιησης της καθε επιχειρησης

$$\max_{\hat{A}} \Pi = p\hat{A} - w\hat{X} = \begin{cases} 0 & \text{if } \hat{A} = 0 \\ p\hat{A} - wF - w\frac{\hat{A}^2}{2} & \text{if } \hat{A} > 0 \end{cases}$$

● maxima of the profit function

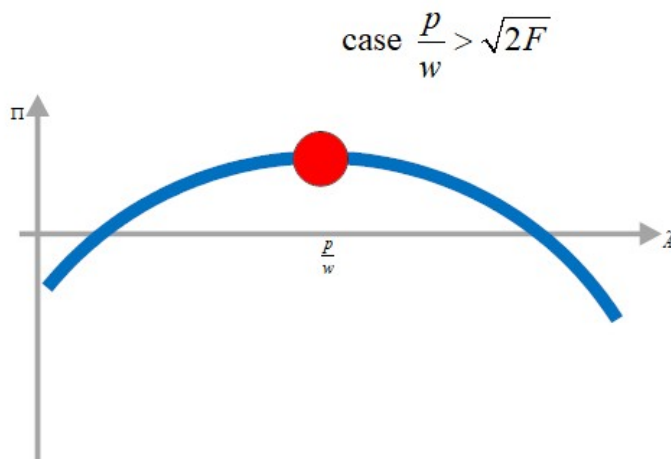
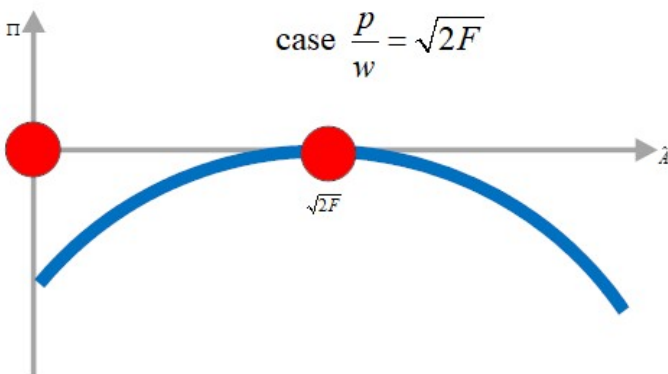
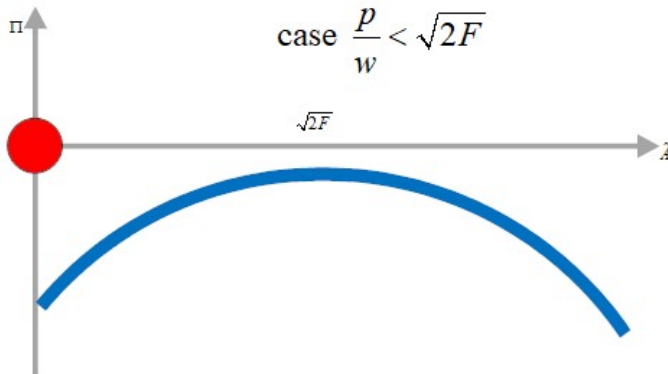

Οι λύσεις των προβλημάτων αυτών είναι οι συναρτήσεις προσφοράς-ζήτησης της κάθε επιχείρησης

$$(\hat{A}, \hat{X}, \Pi) = \begin{cases} (0, 0, 0) & \text{if } \frac{P}{w} < \sqrt{2F} \\ \{(0, 0, 0), (\sqrt{2F}, 2F, 0)\} & \text{if } \frac{P}{w} = \sqrt{2F} \\ \left(\frac{P}{w}, F + \frac{1}{2}\left(\frac{P}{w}\right)^2, \frac{P^2}{2w} - wF\right) & \text{if } \frac{P}{w} > \sqrt{2F} \end{cases} \quad (3)$$

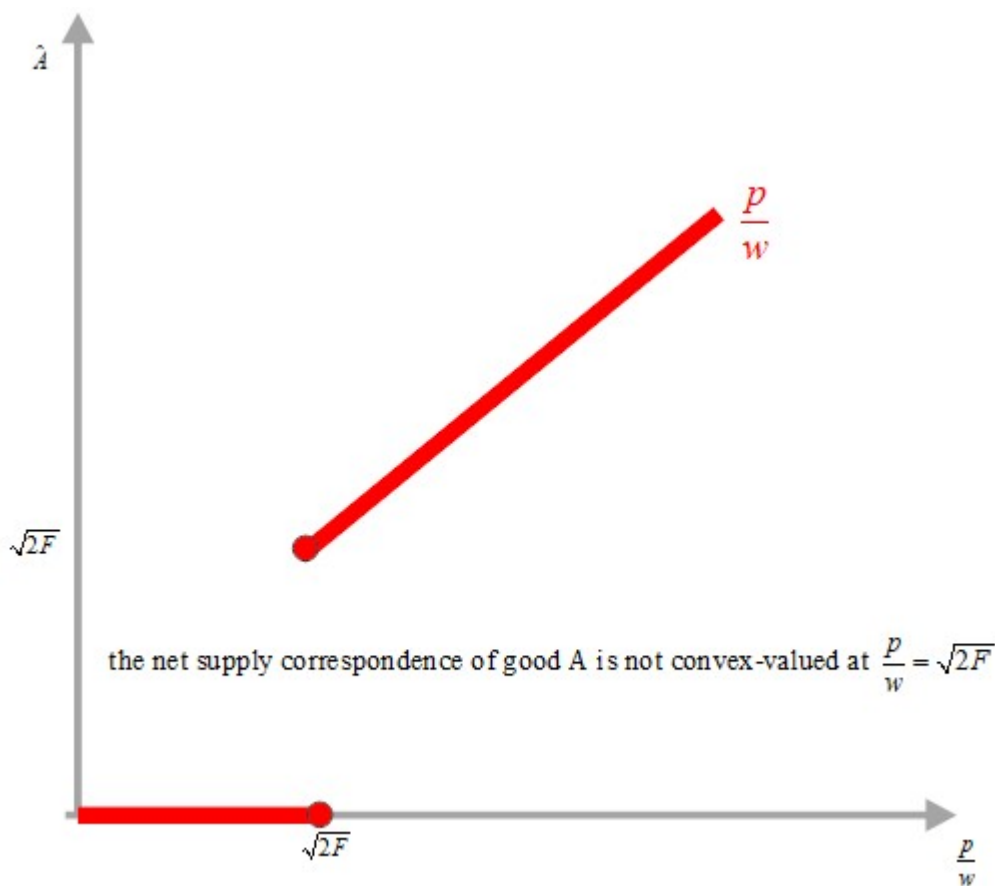

λύνω το πρόβλημα μεγιστοποίησης του κάθε καταναλωτή

$$\max_{A, X} u = \alpha \log A + (1 - \alpha) \log X \quad \text{subject to } pA + wX \leq w\bar{X} + \Pi, A \geq 0, X \geq 0$$

Οι λύσεις των προβλημάτων αυτών είναι οι συναρτήσεις προσφοράς-ζήτησης του κάθε καταναλωτή

$$(A, X) = \left(\alpha \frac{w\bar{X} + \Pi}{p}, (1 - \alpha) \frac{w\bar{X} + \Pi}{w}\right) \quad (4)$$

Απο τις (4),(3) έχουμε οτι τελικά

$$(A, X) = \begin{cases} \begin{bmatrix} \alpha \frac{w\bar{X}}{p} \\ (1-\alpha)\bar{X} \end{bmatrix} & \text{if } \frac{p}{w} \leq \sqrt{2F} \\ \begin{bmatrix} \alpha \left(\frac{w}{p} (\bar{X} - F) + \frac{p}{2w} \right) \\ (1-\alpha) \left(\bar{X} - F + \frac{p^2}{2w^2} \right) \end{bmatrix} & \text{if } \frac{p}{w} > \sqrt{2F} \end{cases} \quad (5)$$

Απο την (5) συμπεραίνουμε οτι η συνάρτηση ζήτησης για το αγαθο A θα είναι

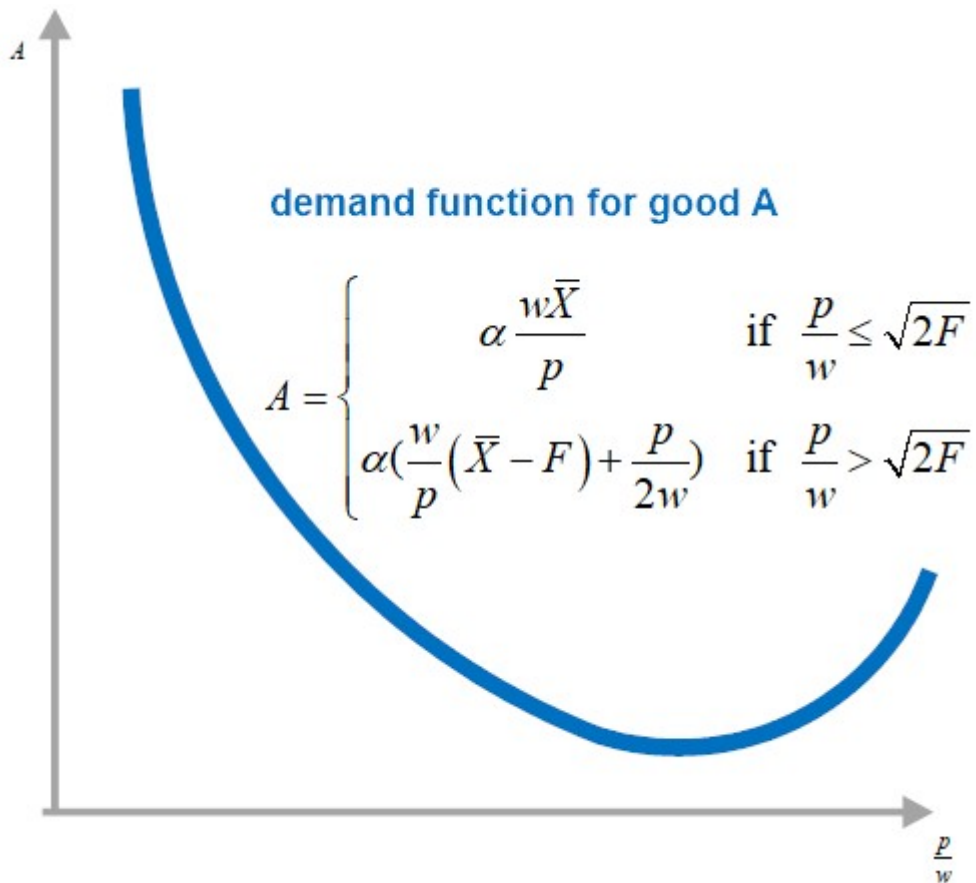

Λύνω τις συνθηκες ισορροπιας

demand	=	supply	
A	=	\hat{A}	(6)
$\hat{X} + X$	=	\bar{X}	

Θα λυσουμε την πρωτη εξισωση με μια διαδικασια αναζητησης. Η μοναδικη μεταβλητη ειναι η σχετικη τιμη $\frac{p}{w}$.

διαδικασια αναζητησης 'υποθεση-λυση-ελεγχος'

υποθεση υπαρχει ισορροπια με $\frac{p}{w} < \sqrt{2F}$

λυση θα πρεπει να εχουμε $\alpha \frac{w\bar{X}}{p} = 0$. Η μοναδικη λυση ειναι η $\frac{w}{p} = 0$

ελεγχος Αντιφαση, διοτι παραβιαζεται η υποθεση $\frac{p}{w} < \sqrt{2F}$

Η αναζητηση ισορροπιων συνεχιζεται με νεα υποθεση

υποθεση υπαρχει ισορροπια με $\frac{p}{w} = \sqrt{2F}$

λυση θα πρεπει να εχουμε $\alpha \frac{w\bar{X}}{p} = \sqrt{2F}$, δηλαδη $\frac{p}{w} = \frac{\alpha\bar{X}}{\sqrt{2F}}$

ελεγχος θα πρεπει να ισχυει η συνθηκη επι των παραμετρων $\sqrt{2F} = \frac{\alpha\bar{X}}{\sqrt{2F}}$

equilibrium prices	
$\frac{p}{w} =$	$\left\{ \begin{array}{ll} \sqrt{2F} & \text{if } \alpha\bar{X} = 2F \\ ? & \text{if } \alpha\bar{X} < 2F \\ ? & \text{if } \alpha\bar{X} > 2F \end{array} \right.$

(7)

Επειδη δεν εχουμε εξαντλησει τον παραμετρικο χωρο, συνεχιζουμε την

αναζητηση ισορροπιων με νεα υποθεση, εως στου καλυφθουν οι περιπτωσεις

$\alpha\bar{X} < 2F, \alpha\bar{X} > 2F$

υποθεση υπαρχει ισορροπια με $\frac{p}{w} > \sqrt{2F}$

λυση θα πρεπει να εχουμε $\alpha \left(\frac{w}{p} (\bar{X} - F) + \frac{p}{2w} \right) = \frac{p}{w}$, δηλαδη $\frac{p}{w} = \sqrt{\frac{2\alpha}{2-\alpha}} \sqrt{\bar{X} - F}$

ελεγχος θα πρέπει να ισχύει η συνθήκη επί των παραμετρών $\sqrt{\frac{2\alpha}{2-\alpha}}\sqrt{\bar{X}-F} > \sqrt{2F}$
,δηλαδή $\alpha\bar{X} > 2F$

equilibrium prices	
$\frac{p}{w} =$	$\begin{cases} \sqrt{2F} & \text{if } \alpha\bar{X} = 2F \\ \sqrt{\frac{2\alpha}{2-\alpha}}\sqrt{\bar{X}-F} & \text{if } \alpha\bar{X} > 2F \\ ? & \text{if } \alpha\bar{X} < 2F \end{cases}$

(8)

Εχουμε εξαντλήσει τις περιπτώσεις για το $\frac{p}{w}$ χωρίς να βρούμε ισορροπία για την περίπτωση $\alpha\bar{X} < 2F$, αρα

equilibrium prices	
$\frac{p}{w} =$	$\begin{cases} \sqrt{2F} & \text{if } \alpha\bar{X} = 2F \\ \sqrt{\frac{2\alpha}{2-\alpha}}\sqrt{\bar{X}-F} & \text{if } \alpha\bar{X} > 2F \\ \text{no equilibrium exists} & \text{if } \alpha\bar{X} < 2F \end{cases}$

(9)

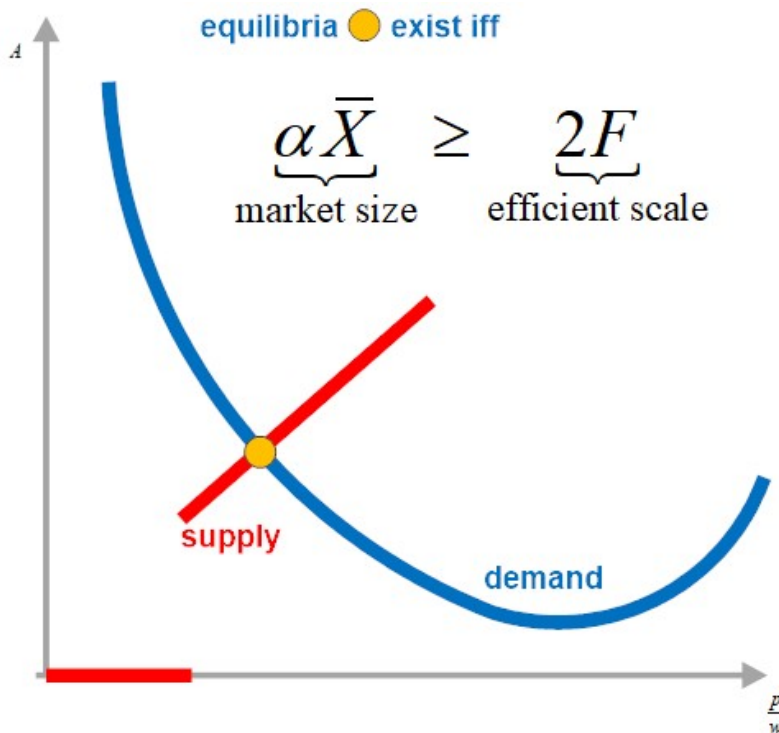

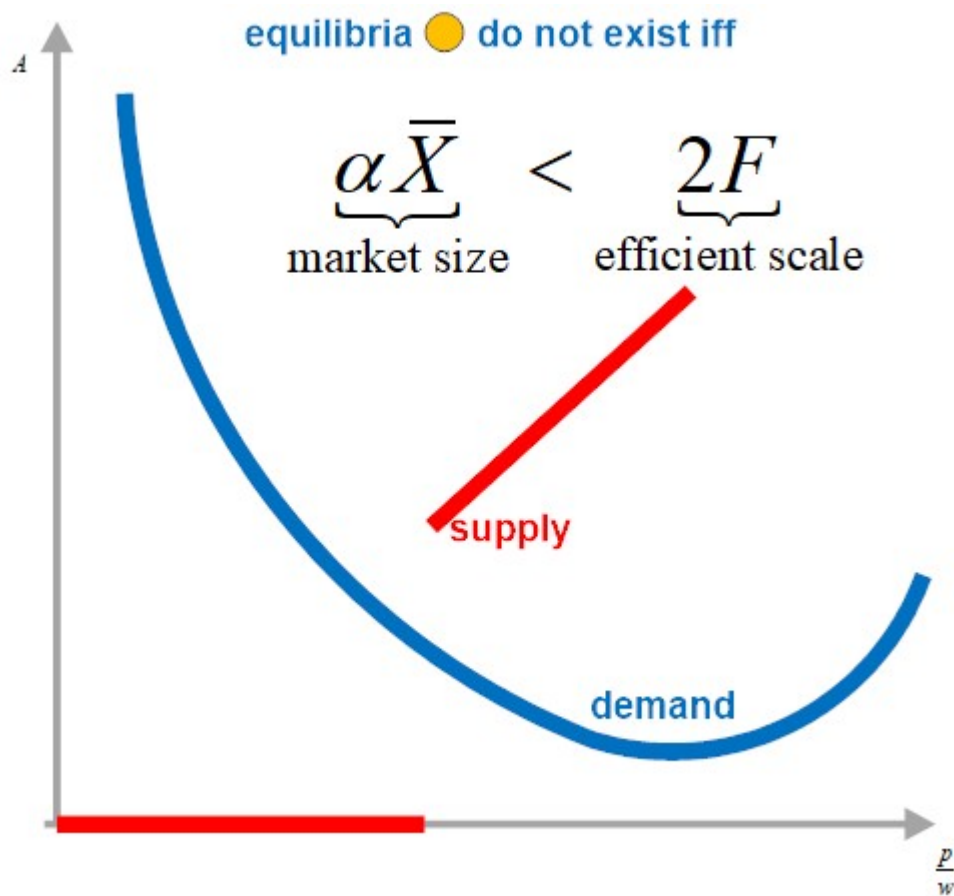

ΠΑΡΑΔΕΙΓΜΑ 3. Nonconvex preferences

Θεωρούμε ανταλλακτική οικονομία με

- τρεις καταναλωτές, τους A, B, C
- δύο αγαθά, τα 1 και 2
- Ο κάθε καταναλωτής έχει μια μονάδα από το κάθε αγαθό
- Οι προτιμήσεις των καταναλωτών είναι ίδιες μεταξύ τους και περιγράφονται από τις ΜΗ ΟΙΟΝΕΙ-ΚΟΙΛΕΣ συναρτήσεις οφέλους

$$U_A = A_1^2 + A_2^2, U_B = B_1^2 + B_2^2, U_C = C_1^2 + C_2^2$$

the utility function $u=x^2+y^2$ has
nonconvex better-than sets

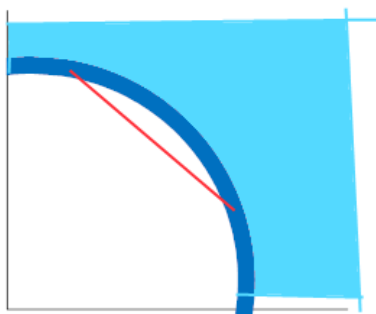

ΥΠΟΛΟΓΙΣΜΟΣ ΑΝΤΑΓΩΝΙΣΤΙΚΗΣ ΙΣΟΡΡΟΠΙΑΣ

ονομαζω την τιμη του καθε αγαθου

p_1, p_2

Οριζω το εισοδημα του καθε καταναλωτη

$$m_A = m_B = m_C = p_1 + p_2 \quad (10)$$

λυνω το προβλημα μεγιστοποιησης του καθε καταναλωτη

παιρουμε τη λυση απο το παραδειγμα 10 της διαλεξης για τη μεγιστοποιηση

$$(A_1, A_2) = (B_1, B_2) = (C_1, C_2) = \begin{cases} \left(\frac{p_1 + p_2}{p_1}, 0\right) & \text{if } p_1 < p_2 \\ \left\{ \left(\frac{p_1 + p_2}{p_1}, 0\right), \left(0, \frac{p_1 + p_2}{p_2}\right) \right\} & \text{if } p_1 = p_2 \\ \left(0, \frac{p_1 + p_2}{p_2}\right) & \text{if } p_1 > p_2 \end{cases} \quad (11)$$

Με την αλλαγη μεταβλητης $p = \frac{p_1}{p_2}$, η (12) παιρνει την απλουστερη μορφη

$$(A_1, A_2) = (B_1, B_2) = (C_1, C_2) = \begin{cases} \left(1 + \frac{1}{p}, 0\right) & \text{if } p < 1 \\ \{(2, 0), (0, 2)\} & \text{if } p = 1 \\ (0, 1 + p) & \text{if } p > 1 \end{cases} \quad (12)$$

Demand function of consumer A for good 1

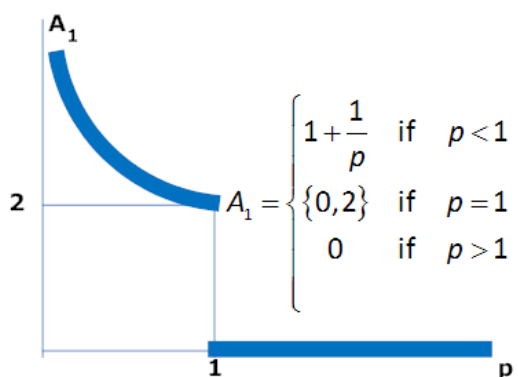

λύνω τις συνθήκες ισορροπίας

demand	=	supply	
$A_1 + B_1 + C_1$	=	3	(13)
$A_2 + B_2 + C_2$	=	3	

διαδικασία αναζήτησης 'υποθεση-λυση-ελεγχος'

υποθεση υπάρχει ισορροπία με $p < 1$

λυση Η δεύτερη εξίσωση γίνεται $0=3$

ελεγχος αντιφάση

Νέα υποθεση υπάρχει ισορροπία με $p > 1$

λυση Η πρώτη εξίσωση γίνεται $0=3$

ελεγχος αντιφάση

Νέα υποθεση υπάρχει ισορροπία με $p = 1$

λυση εάν όλοι οι καταναλωτές επιλέξουν το ίδιο αγαθό, έχουμε πάλι την αντιφάση $0=3$. εάν δύο καταναλωτές επιλέξουν το ίδιο αγαθό, και ο τρίτος το άλλο αγαθό, οι εξισώσεις ισορροπίας γίνονται $4 = 3, 2 = 3$

ελεγχος αντιφάση

Επειδή έχουμε εξαντλήσει τις περιπτώσεις για τις τιμές χωρίς να έχουμε βρει λύση συμπεραίνουμε ότι δεν υπάρχει ισορροπία. Διαγραμματικά έχουμε ότι

competitive equilibria do not exist

Aggregate demand function for good 1

Aggregate supply function for good 1

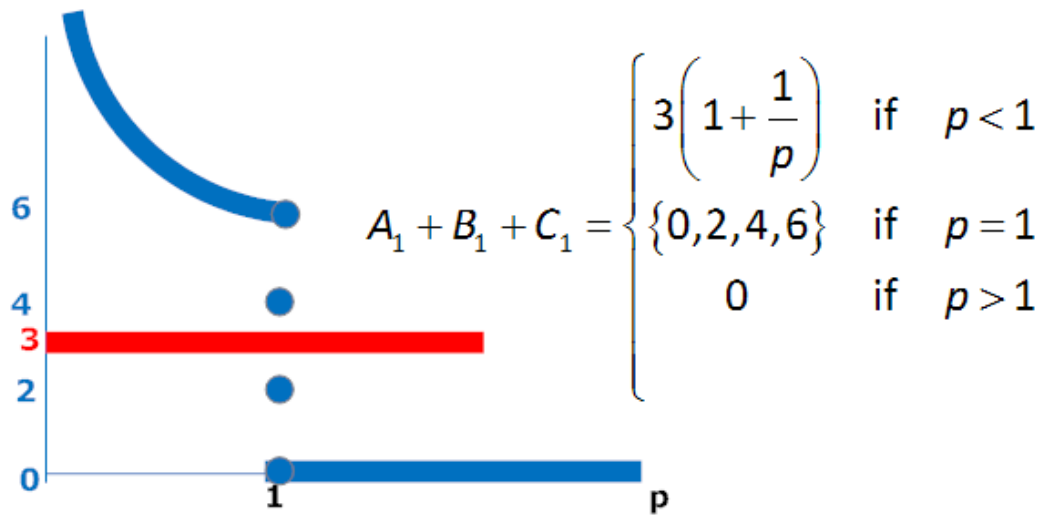

1. THE ECONOMY

- Two consumers, 1 and 2
- Two goods, food (f) and labour services (s)
- Preferences $u_i = 2\sqrt{f_i} + 2\sqrt{s_i}$
- Endowments $e_1 = (0, 1)$, $e_2 = (f, 0)$ (The first entry represents food)
- Consumer 1, in order to supply labour services $1 - s_1$, needs to consume at least $f_1 \geq 1 - s_1$.

2. COMPETITIVE EQUILIBRIUM

1. NAME THE PRICE OF EACH GOOD

p = price of f , w = price of s

2. NORMALIZE PRICES (OPTIONAL)

$p = 1$

3. SOLVE THE OPTIMIZATION PROBLEMS OF CONSUMERS

$\max u_1 = 2\sqrt{f_1} + 2\sqrt{s_1}$, subject to $f_1 \geq 1 - s_1$, $f_1 + ws_1 \leq w$ yields

$$(s_1, f_1) = \begin{cases} \left(\frac{1}{1+w}, \frac{w^2}{1+w} \right) & \text{if } w \geq 1 \\ (1, 0) & \text{if } w < 1 \end{cases} \quad (1)$$

feasible set of consumer 1

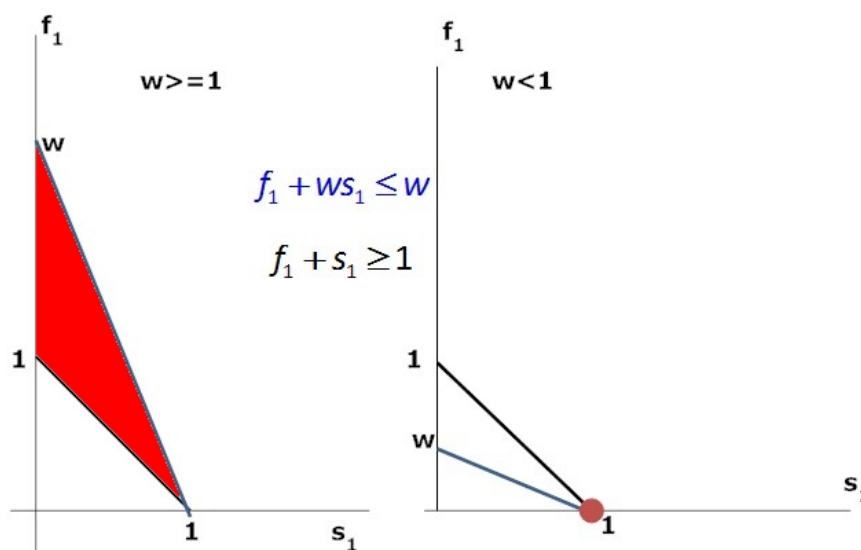

$\max u_2 = 2\sqrt{f_2} + 2\sqrt{s_2}$, subject to $f_2 + ws_2 \leq f$ yields

$$(s_2, f_2) = \left(\frac{f}{(1+w)w}, \frac{wf}{(1+w)} \right) \quad (2)$$

4. Solve the equilibrium conditions

$$s_1 + s_2 = 1, f_1 + f_2 = f \quad (3)$$

By(3),(2),(1) we obtain

$$\begin{aligned} \text{if } f < 1 \text{ then no equilibrium exists} \\ \text{if } f \geq 1 \text{ then there is one equilibrium, namely } w = \sqrt{f} \end{aligned} \quad (4)$$

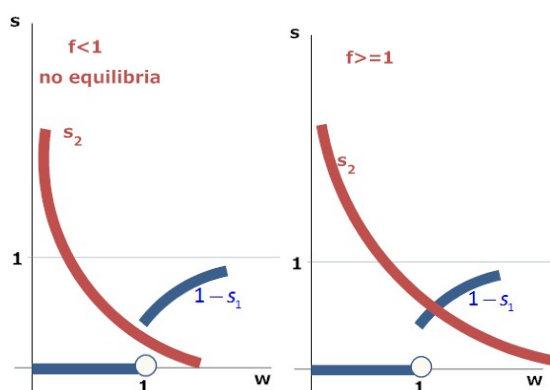

The situation in the case $f < 1$ is described as a poverty trap.

3. COMPETITIVE EQUILIBRIUM WITH LUMP-SUM TRANSFERS WHEN $F < 1$

Consumer 1 receives a positive transfer $T < f$, paid by Consumer 2.

1. NAME THE PRICE OF EACH GOOD

$p =$ price of f , $w =$ price of s

2. NORMALIZE PRICES (OPTIONAL)

$p = 1$

3. SOLVE THE OPTIMIZATION PROBLEMS OF CONSUMERS

$\max u_1 = 2\sqrt{f_1} + 2\sqrt{s_1}$, subject to $f_1 \geq 1 - s_1, f_1 + ws_1 \leq w + T$ yields

$$(s_1, f_1) = \begin{cases} \left(\frac{w+T}{w(1+w)}, \frac{w(w+T)}{1+w} \right) & \text{if } T \geq \frac{w^2(1-w)}{1+w^2} \\ \left(1 - \frac{T}{1-w}, \frac{T}{1-w} \right) & \text{if } T < \frac{w^2(1-w)}{1+w^2} \end{cases} \quad (5)$$

$\max u_2 = 2\sqrt{f_2} + 2\sqrt{s_2}$, subject to $f_2 + ws_2 \leq f - T$ yields

$$(s_2, f_2) = \left(\frac{f-T}{(1+w)w}, \frac{w(f-T)}{(1+w)} \right) \quad (6)$$

4. Solve the equilibrium conditions

$$s_1 + s_2 = 1, f_1 + f_2 = f \quad (7)$$

The equation $\frac{w+T}{w(1+w)} + \frac{f-T}{(1+w)w} = 1$ has the unique solution $w = \sqrt{f}$. The condition

$T \geq \frac{w^2(1-w)}{1+w^2}$ then becomes $T \geq \frac{f(1-\sqrt{f})}{1+f}$. Hence

$$\text{for } f > T \geq \frac{f(1-\sqrt{f})}{1+f} \text{ there is an equilibrium, namely } w = \sqrt{f} \quad (8)$$

(Non)-Existence of Walrasian Equilibrium

KC Border*
January 2000
v. 2017.10.23::12.17

A *private ownership economy* \mathcal{E} is a tuple $((X_i, \succsim_i, \omega^i)_{i=1}^m, (Y_j)_{j=1}^n, (\theta_j^i)_{j=1, \dots, n}^{i=1, \dots, m})$, as described in [my notes on the Arrow–Debreu model](#). The following is a typical theorem for the existence of a Walrasian equilibrium, based on Debreu [13, pp. 83–84]. I have rewritten some of the conditions to make them independent of each other. Weaker conditions can be imposed to obtain the same result, at the expense of simplicity.

Theorem 1 *The private ownership economy \mathcal{E} has a Walrasian equilibrium if all of the following conditions are satisfied.*

1. *Conditions on consumption sets.*

- (a) *Each X_i is closed.*
- (b) *Each X_i is convex.*
- (c) *Each X_i is bounded below.*

2. *Conditions on preferences.*

- (a) *Each \succsim_i is nonsatiated.*
- (b) *Each \succsim_i is continuous.*
- (c) *Preferences are convex. That is, if $x \succsim_i y$, then for every $\lambda \in (0, 1)$ we have $\lambda x + (1 - \lambda)y \succsim_i y$ (provided $\lambda x + (1 - \lambda)y \in X_i$).¹*

3. *Condition on endowments:*

For each i there exists $\hat{x}^i \in X_i$ such that $\omega^i \gg \hat{x}^i$.

4. *Conditions on production.*

- (a) *There is a possibility of inaction. That is, $0 \in Y_j$ for each j .*
- (b) *The aggregate production set $Y = \sum_{j=1}^n Y_j$ is closed.*
- (c) *The aggregate production set $Y = \sum_{j=1}^n Y_j$ is convex.*
- (d) *Production is irreversible. That is, $Y \cap (-Y) \subset \{0\}$.*
- (e) *There is free disposability. That is, if $y \in Y$, then $\{y\} - \mathbf{R}_+^\ell \subset Y$.²*

*I thank Gábor Uhrin for pointing out typos in an earlier draft.

¹The provision is explicit so that violations of condition 1b do not imply a violation of 2c.

²This condition is usually written as $-\mathbf{R}_+^\ell \subset Y$. This formulation makes it easier to construct economies satisfying free disposability and irreversibility, yet violating the possibility of inaction.

1 Why do we need the assumptions?

I claim that each of the following examples satisfies all but one of the conditions of Theorem 1 and Walrasian equilibrium fails to exist. This does not of course imply that each condition is necessary for the existence of equilibrium. Indeed some of these conditions can be replaced by weaker assumptions, albeit at the cost of a more difficult proof. Each example is designed to show the sort of phenomenon that must be addressed. The examples are intended to be simple rather than realistic. Also, they make use of straight lines whenever possible, since they are easy to draw and specify exactly.

To simplify the description of an economy, let us agree that a *pure exchange economy* has $n = 1$ and $Y = Y_1 = -\mathbf{R}_+^\ell$. A pure exchange economy satisfies all the assumptions on production. A pure exchange economy with two consumers and two commodities, where $X_1 = X_2 = \mathbf{R}_+^2$, will be called an *Edgeworth box* economy.

Many of these examples are easy visualize. In the following diagrams, indifference curves for consumer 1 will be orange and his offer curve will be red. Consumer 2 will have green indifference curves and blue offer curve. Let us hope you have a color printer. Where convenient I shall replace preference relations by utility functions.

Note that in a pure exchange economy as I have just defined it, if there is a Walrasian equilibrium, then the equilibrium price vector must be nonnegative, otherwise the producer will have no profit maximum. This means we only need consider nonnegative price vectors. Also note that if someone has a locally nonsatiated preference, then an equilibrium price vector cannot be zero, for demand will be unbounded. Note that nonsatiation, together with convexity of preference and convexity of the consumption set imply local nonsatiation.

Assumption 1a: Closed consumption sets

When consumption sets are not closed, the problem is that a preference maximum might not exist. Consider the trivial case of a one person, one commodity, pure exchange economy, where

$$X = [0, 1), \quad \omega = 1, \quad u(x) = x.$$

Assumption 1b: Convex consumption sets

In this two person example there are two locations, Los Angeles and St. Louis, and one commodity, football. It is impossible to consume football in both Los Angeles and St. Louis—a choice must be made. Thus the consumption set for each consumer is

$$X = \{(x, y) \in \mathbf{R}_+^2 : x = 0 \text{ or } y = 0\},$$

where x is football in L.A. and y is football in St.L. Assume preferences on X are given by

$$u(x, y) = 2x + y.$$

Let the endowment be

$$\omega^1 = \omega^2 = (1, 1).$$

Let the aggregate production set Y be the negative orthant $-\mathbf{R}_+^2$, so that there is free disposal.

You might ask how one could be endowed with football in both locations. Think of the endowment as tickets—you could have title to tickets in both locations, but can attend games in only one.

Since preferences are monotonic, prices must be nonnegative. If $p_x > 2p_y$, both consumers will wish to sell their x endowment and consume only y , so this cannot be an equilibrium. If $p_x < 2p_y$, both consumers will wish to sell their y endowment and consume only x , so this cannot be an equilibrium. If $p_x = 2p_y$, each consumer is indifferent to $(0, 3)$ and $(\frac{3}{2}, 0)$. No combination of these adds up to the endowment $(2, 2)$, so this cannot be an equilibrium. See Figure 1.

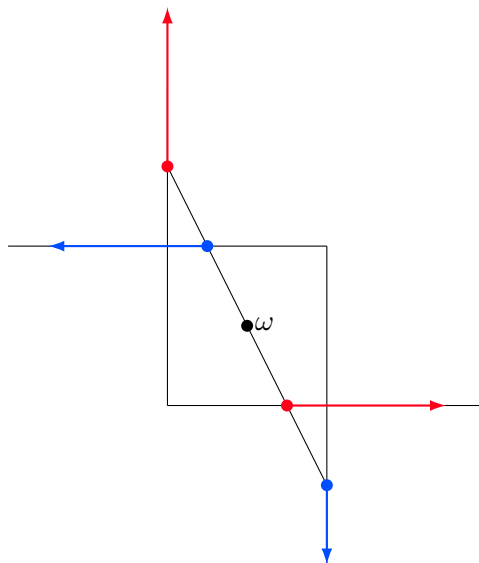

Figure 1. Offer curves for location-specific football.

Assumption 1c: Consumption sets bounded below

Modify an Edgeworth box economy so that $X_1 = \{(x, y) : y \geq 0\}$. That is, consumer 1 can supply unboundedly large amounts of x . Set $u_1(x, y) = y$, $u_2(x, y) = x + y$, and $\omega^1 = \omega^2 = (1, 1)$. Since X_1 is unbounded below in x , if $p_x > 0$, then consumer 1 will have unbounded income to spend on y , so an equilibrium price must have $p_x = 0$, but then consumer 2, will have an unbounded demand for x , so no equilibrium exists.

Assumption 2a: Nonsatiation

It is clear that if there is a satiation point, then monotonicity must be violated, so why don't we go all the way and give consumer 1 antimonotonic preferences. Specifically, suppose we have an Edgeworth box economy with

$$u_1(x, y) = -(x + y) \quad u_2(x, y) = x + y$$

and $\omega^1 = \omega^2 = (1, 1)$. Note that consumer 1 always demands $(0, 0)$ when prices are nonnegative, but consumer 2 cannot afford to consume $(2, 2)$, so no nonnegative price vector clears the market.

Assumption 2b: Continuous preferences

To see what can happen when preferences are not continuous consider the following Edgeworth box economy. The preferences of both consumers are given by

$$(x, y) \succ (x', y') \iff x + y > x' + y' \text{ or } (x + y = x' + y' \ \& \ x \geq x').$$

That is, the preferences are lexicographically increasing, first in the sum, and then in x (see Figure 2a). If endowments are $\omega^1 = \omega^2 = (1, 1)$, then the offer curve for each consumer is shown in Figure 2b. If $p_x > p_y$, then no one demands x , but if $p_x \leq p_y$, then no one demands y . The offer curves leap over each other at $p_x = p_y$ (Figure 2c).

Assumption 2c: Convex preferences

Consider the following Edgeworth box economy. The endowments are

$$\omega^1 = (1, 1), \quad \omega^2 = (1, 1).$$

Consumers have preferences represented by the utility functions

$$u_1(x, y) = \max\{\min\{x, \frac{1}{2}y\}, \min\{\frac{1}{2}x, y\}\} \quad u_2(x, y) = \min\{x, y\}.$$

Sample indifference curves for consumer 1's preferences are shown in Figure 3a. Consumer 2 always demands his endowment, unless a price is zero. See Figure 3b. The box is shown in Figure 3c, and it is clear that no equilibrium exists.

Assumption 3: Endowments

To see what can happen when the endowment condition is violated consider the following Edgeworth box economy. The utility functions are

$$u^1(x, y) = x + y, \quad u^2(x, y) = \min\{x, y\},$$

and the endowments are

$$\omega^1 = (1, 0), \quad \omega^2 = (2, 1).$$

The Edgeworth box diagram for this economy is shown in Figure 4a.

To see that there is no equilibrium, notice that consumer 1's preferences are strictly monotonic, so in equilibrium both prices must be strictly positive. When both prices are strictly positive, the offer curves are shown in Figure 4b. Since these do not intersect, there is no Walrasian equilibrium. Note however that the endowment is a quasi-equilibrium.

Note also that consumer 2's preferences are not strictly monotonic. This is necessary for this example. Indeed McKenzie [29, 30] offers an alternative to the endowment condition, called *irreducibility*, that is automatically satisfied if preferences are strictly monotonic and every consumer is endowed with at least one good.

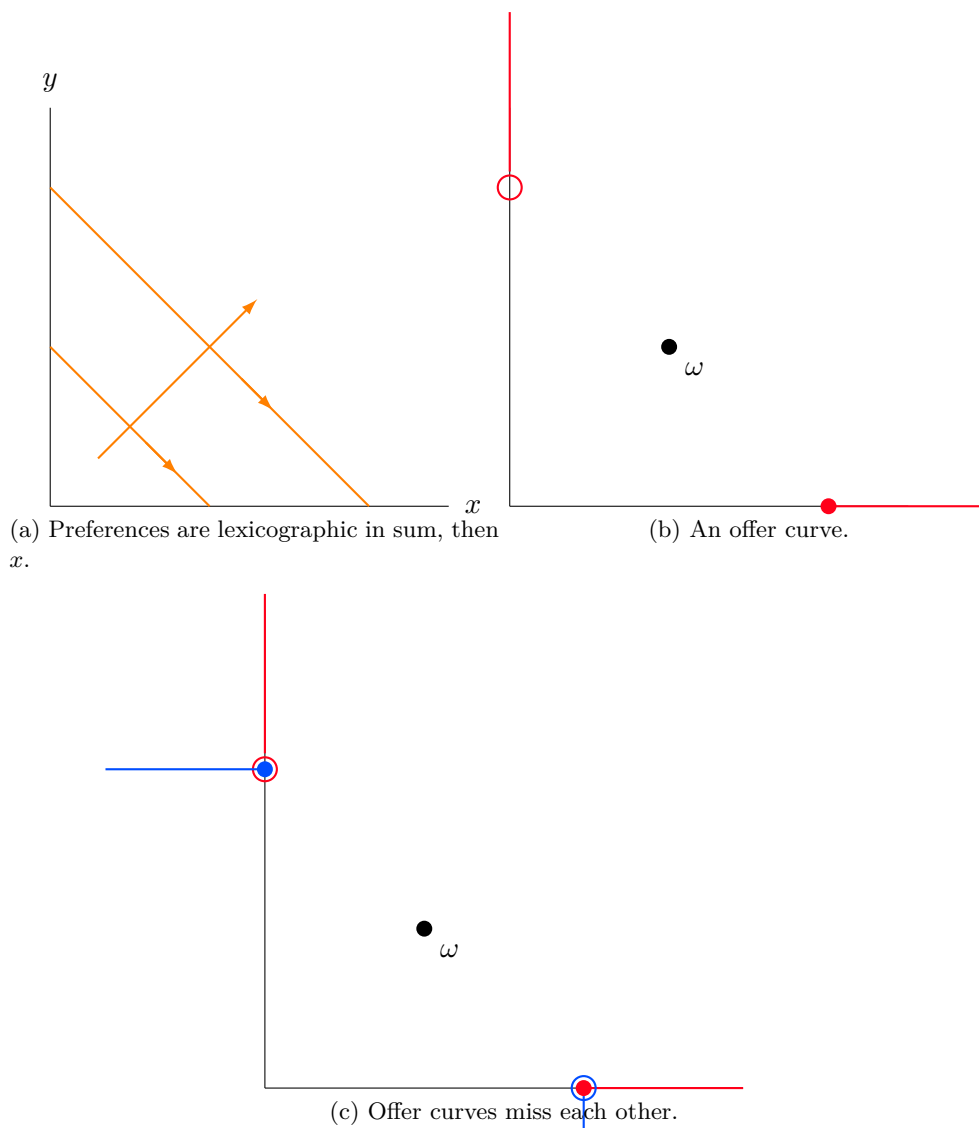
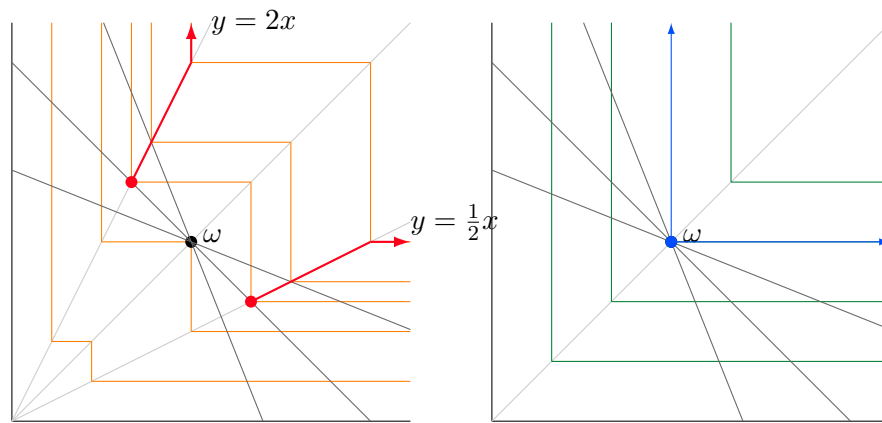
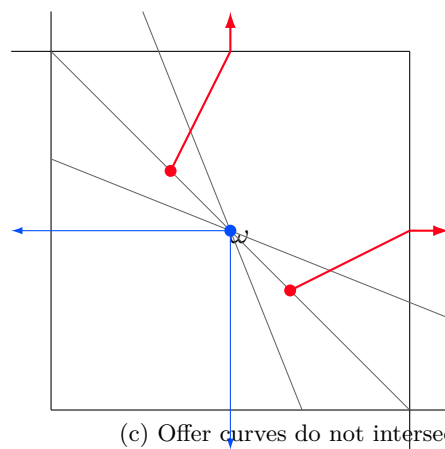

Figure 2. Example where preferences are not continuous.



(a) $u(x, y) = \max\{\min\{x, \frac{1}{2}y\}, \min\{\frac{1}{2}x, y\}\}.$

(b) $u(x, y) = \min\{x, y\}.$



(c) Offer curves do not intersect.

Figure 3. Failure of equilibrium with non-convex preferences.

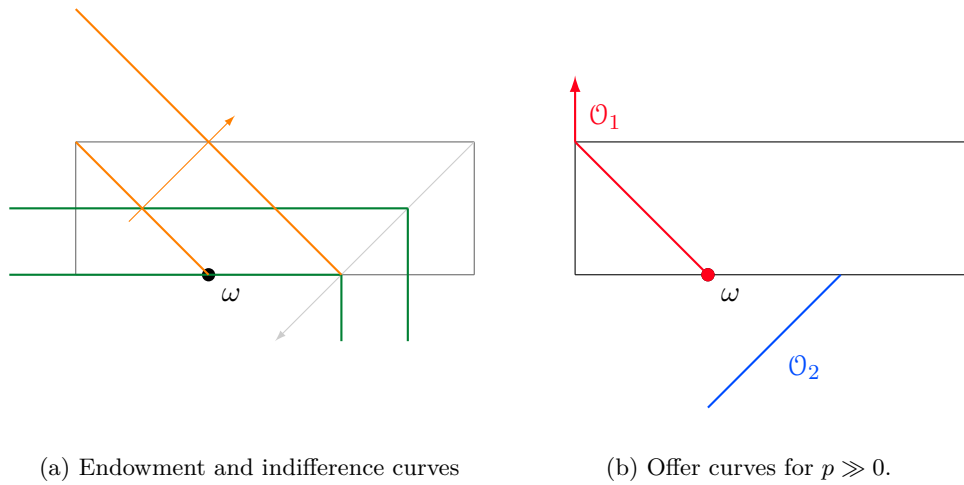

Figure 4. Example with endowment on boundary.

The endowment condition has other implications. For instance, it is the only condition that guarantees that the consumption set is nonempty! (Nonsatiation does not guarantee it, since the empty set has no satiation points.) Even if we explicitly assume that consumption sets are nonempty, there may still be no feasible allocations if the endowment condition is violated. For instance, consider the one person, one commodity pure exchange economy with endowment zero, and consumption set $X = [1, \infty)$.

Assumption 4a: Possibility of inaction

For the examples on production, for simplicity let there be only one consumer with consumption set $X = \mathbf{R}_+^2$, endowment $\omega = (1, 1)$, and utility $u(x, y) = x + y$.

For a counterexample without the possibility of inaction, let there be one producer with production possibility set

$$Y = \{(x, y) : x \leq -2, y \leq -2\}.$$

Then note that $X \cap (Y + \omega) = \emptyset$. That is, there are no feasible allocations, and hence no equilibria.

For an even cheaper example, let $Y = \emptyset$. Then no allocations exist. Note that free disposability as I have defined it is still satisfied.

Assumption 4b: Closure of production set

Again let there be only one consumer with consumption set $X = \mathbf{R}_+^2$, endowment $\omega = (1, 1)$, and utility $u(x, y) = x + y$. Let there be one producer with production possibility set

$$Y = \{(x, y) : y < (-x)^{\frac{1}{2}}, x \leq 0\}.$$

That is, y is produced from x , and the production function is almost $y = x^{\frac{1}{2}}$. But in fact, $x^{\frac{1}{2}}$ is an upper bound that can never be attained. As long as $p_y > 0$, there is no profit maximizer.

When $p_y = 0$, then $(0, 0)$ is a profit maximizer, but demand for y is unbounded. Therefore no equilibrium exists.

Assumption 4c: Convexity of production set

Again let there be only one consumer with consumption set $X = \mathbf{R}_+^2$, endowment $\omega = (1, 1)$, and utility $u(x, y) = x + y$. Instead of an indivisible commodity, we shall examine an example with increasing returns to scale. In such an example, as long as the price of output is positive, profit is increasing in output, so no maximum can exist. Almost any production function with globally increasing returns to scale will do, but in keeping with the use of straight lines, for $n = 0, 1, 2, \dots$, set

$$F_n = \{(x, y) : y \leq -nx, x \leq -n\} \quad Y = \bigcup_{n=0}^{\infty} F_n.$$

See Figure 5. Then profit is unbounded for any nonnegative price vector with $p_y > 0$. But $p_y = 0$ leads to unbounded demand for good y , so it cannot yield an equilibrium either.

Assumption 4d: Irreversibility

The assumptions of irreversibility and free disposability together imply that no production vector is nonnegative. That is, it takes inputs to produce output. There are other assumptions that guarantee this, and Debreu [14] shows that irreversibility can be replaced by another condition, namely that the recession cones of the production and consumption sets are positively semi-independent, but let's not go into that here. Moreover, Bergstrom [6] shows how to discard 'free disposability'—at no cost. As a result, the examples given here are what my son would call “cheap,” that is, they are easily ruled out by alternative assumptions that may be even more plausible.

Let there be only one consumer with consumption set $X = \mathbf{R}_+^2$, endowment $\omega = (1, 1)$, and utility $u(x, y) = x + y$. There is one producer with $Y = \{(x, y) : x \leq 0\}$. The only price vectors for which a profit maximizer exists must have $p_y = 0$, and they lead to unbounded demand for y .

Assumption 4e: Free disposability

Let there be only one consumer with consumption set $X = \mathbf{R}_+^2$, endowment $\omega = (1, 1)$, and utility $u(x, y) = x + y$. There is one producer with $Y = \mathbf{R}_+^2$. The only price vectors p for which a profit maximizer exists must have $p \leq 0$, and they lead to unbounded demands.

2 An outline of a proof

Here is a sketch of one method of proof, leaving out the details. I call this the excess demand approach. There are other approaches. A key ingredient in all the methods I know is the following theorem. See Border [9, Theorem 12.1] or [my on-line notes](#) for a proof.

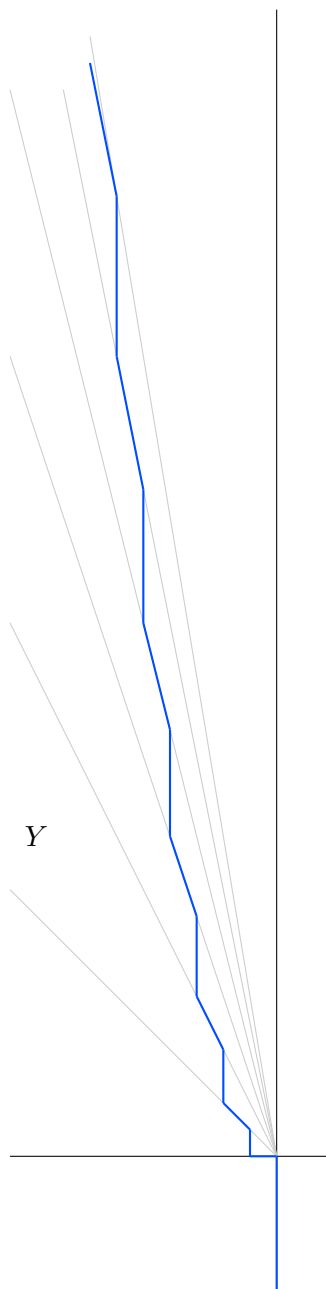

Figure 5. Increasing returns to scale.

Berge Maximum Theorem *Let P, X be metric spaces and let $\varphi: P \rightarrow X$ be a correspondence with nonempty compact values. Let $f: X \times P \rightarrow \mathbf{R}$ be continuous. Define the “argmax” correspondence $\mu: P \rightarrow X$ by*

$$\mu(p) = \{x \in \varphi(p) : x \text{ maximizes } f(\cdot, p) \text{ on } \varphi(p)\},$$

and the value function $V: P \rightarrow \mathbf{R}$ by

$$V(p) = f(x, p) \quad \text{for any } x \in \mu(p).$$

If φ is continuous at p , then μ is closed and upper hemicontinuous at p and V is continuous at p . Furthermore, μ is compact-valued.

Normalize prices so that $\sum_{k=1}^{\ell} p_k = 1$. This can be done as long as we can restrict attention to nonnegative prices, which we can by free disposability. Thus let

$$\Delta = \{p \in \mathbf{R}^{\ell} : p \geq 0, \sum_{k=1}^{\ell} p_k = 1\}.$$

In order to use the Berge Maximum Theorem as stated, we need some compactness, so for the time being, assume that each X_i and each Y_j is compact. (Later we shall see how to drop this assumption, which is incompatible, for instance, with free disposability.)

Step 1: For each producer j , let

$$\eta^j(p) = \{y \in Y^j : p \cdot y \geq p \cdot y' \text{ for all } y' \in Y^j\},$$

be the supply correspondence of producer j , and let

$$\pi^j(p) = \max\{p \cdot y : y \in Y^j\}$$

be the profit function. The Berge Maximum Theorem implies that η^j is an upper hemicontinuous correspondence and π^j is a continuous function. Also, since $0 \in Y^j$, we have $\pi^j(p) \geq 0$ for all p . Convexity of Y implies that $\sum_{j=1}^n \eta^j$ is convex-valued.

Step 2: Now for each consumer i , define

$$m^i(p) = p \cdot \omega^i + \sum_{j=1}^n \theta_j^i \pi^j(p),$$

consumer i 's income at price vector p . Since we have assumed $\omega^i \gg \hat{x}^i$, we have $p \cdot \hat{x}^i < m^i(p)$ for $p \in \Delta$. Thus the budget correspondence

$$\beta^i(p) = \{x \in X^i : p \cdot x \leq m^i(p)\}$$

is a continuous correspondence (this requires proof), so by the Berge Maximum Theorem, the demand correspondence

$$\xi^i(p) = \{x \in \beta^i(p) : x \succsim_i x' \text{ for all } x' \in \beta^i(p)\}$$

is an upper hemicontinuous compact-valued correspondence. By convexity of preferences, it is convex-valued.

Step 3: The **excess demand correspondence**

$$\zeta(p) = \sum_{i=1}^m \xi^i(p) - \sum_{j=1}^n \eta^j(p)$$

is upper hemicontinuous and convex- and compact-valued. (This too requires proof.)

By local nonsatiation, the strong form of Walras' Law,

$$p \cdot z = 0 \text{ for all } z \in \zeta(p),$$

is satisfied. Now use the following theorem due to Gale [19], Kuhn [24], Nikaidô [37], and Debreu [12]. See Border [9, Theorem 18.1] for a proof.

Gale–Debreu–Nikaidô Lemma *Let $\zeta: \Delta \rightarrow \mathbf{R}^\ell$ be an upper hemicontinuous correspondence with nonempty compact convex values satisfying Walras' Law, i.e., for all $p \in \Delta$, $p \cdot z \leq 0$ for each $z \in \zeta(p)$. Then there exists $p \in \Delta$ and $z \in \zeta(p)$ satisfying $z \leq 0$.*

Step 4: Now we can deal with the compactness assumption. Let K_n be an increasing sequence of compact convex sets, each containing each ω^i and each \hat{x}^i , whose union is \mathbf{R}^ℓ . Let $X_n^i = X^i \cap K_n$ and $Y_n^j = Y^j \cap K_n$, and let ζ_n be the excess demand correspondence of this truncated economy. By the lemma, we get a sequence (p_n, z_n) with $z_n \leq 0$ and $z_n \in \zeta_n(p_n)$. Since Δ is compact there is a convergent subsequence, let's also denote it $p_n \rightarrow p \in \Delta$.

An alternative to this is to prove that the set of allocations is compact (not easy) and work within the interior of a single compact set.

By upper hemicontinuity, we can also show there is a further subsequence with $z_n \rightarrow z \leq 0$ and $z \in \zeta(p)$. (This is harder than it looks.) That is, there exist $(x^1, \dots, x^m, y^1, \dots, y^n)$ with each $x^i \in \xi^i(p)$ and $y^j \in \eta^j(p)$ and

$$\sum_{i=1}^m x^i - \sum_{i=1}^m \omega^i - \sum_{j=1}^n y^j = z \leq 0.$$

Step 5: By Walras' Law, $p \cdot z = 0$, and by free disposability $z \in Y$. By the definition of η^j , each y^j maximizes p over Y^j , so $y = \sum_{j=1}^n y^j$ maximizes p over Y . But $p \cdot y = p \cdot (y + z)$, so $y + z$ maximizes p over Y , which means we can write $y + z = \sum_{j=1}^n \tilde{y}^j$, where each \tilde{y}^j maximizes p over Y^j . Thus $(x^1, \dots, x^m, \tilde{y}^1, \dots, \tilde{y}^n; p)$ is a Walrasian equilibrium.

Selected References

- [1] C. D. Aliprantis, K. C. Border, and O. Burkinshaw. 1997. Economies with many commodities. *Journal of Economic Theory* 74(1):62–105. DOI: [10.1006/jeth.1996.2240](https://doi.org/10.1006/jeth.1996.2240)
- [2] K. J. Arrow and G. Debreu. 1954. Existence of an equilibrium for a competitive economy. *Econometrica* 22(3):265–290. <http://www.jstor.org/stable/1907353>

- [3] K. J. Arrow and F. H. Hahn. 1971. *General competitive analysis*. San Francisco: Holden-Day.
- [4] R. J. Aumann. 1966. Existence of competitive equilibria in markets with a continuum of traders. *Econometrica* 34(1):1–17. <http://www.jstor.org/stable/1909854>
- [5] W. Baumol and S. M. Goldfeld, eds. 1968. *Precursors in mathematical economics*. Number 19 in Series of reprints of scarce works on political economy. London: London School of Economics and Political Science.
- [6] T. C. Bergstrom. 1976. How to discard ‘free disposability’—at no cost. *Journal of Mathematical Economics* 3(2):131–134. DOI: 10.1016/0304-4068(76)90021-5
- [7] M. Berliant. 1985. An equilibrium existence result for an economy with land. *Journal of Mathematical Economics* 14(1):53–56. DOI: 10.1016/0304-4068(85)90026-6
- [8] K. C. Border. 1984. A core existence theorem without ordered preferences. *Econometrica* 52(6):1537–1542. <http://www.jstor.org/stable/1913519>
- [9] ———. 1985. *Fixed point theorems with applications to economics and game theory*. New York: Cambridge University Press.
- [10] G. Debreu. 1952. A social equilibrium existence theorem. *Proceedings of the National Academy of Sciences, U.S.A.* 38(10):886–893. <http://www.pnas.org/cgi/reprint/38/10/886>
- [11] ———. 1954. Valuation equilibrium and Pareto optimum. *Proceedings of the National Academy of Sciences, U.S.A.* 40(7):588–592. <http://www.pnas.org/cgi/reprint/40/7/588>
- [12] ———. 1956. Market equilibrium. *Proceedings of the National Academy of Sciences, U.S.A.* 42(11):876–878. <http://www.pnas.org/cgi/reprint/42/11/876>
- [13] ———. 1959. *Theory of value: An axiomatic analysis of economic equilibrium*. Number 17 in Cowles Foundation Monographs. New Haven: Yale University Press. <http://cowles.econ.yale.edu/P/cm/m17/m17-all.pdf>
- [14] ———. 1962. New concepts and techniques for equilibrium analysis. *International Economic Review* 3(3):257–273. <http://www.jstor.org/stable/2525394>
- [15] ———. 1982. Existence of competitive equilibrium. In K. J. Arrow and M. D. Intriligator, eds., *Handbook of Mathematical Economics*, volume 2, chapter 15, pages 697–743. Amsterdam: North Holland.
- [16] B. Ellickson. 1993. *Competitive equilibrium: Theory and applications*. Cambridge and New York: Cambridge University Press.
- [17] M. Florenzano. 1982. The Gale–Nikaidô–Debreu lemma and the existence of transitive equilibrium with or without the free disposal assumption. *Journal of Mathematical Economics* 9(1–2):113–134. DOI: 10.1016/0304-4068(82)90022-2

- [18] ———. 2003. *General equilibrium analysis: Existence and optimality properties of equilibria*. Boston: Kluwer Academic Publishers.
- [19] D. Gale. 1955. The law of supply and demand. *Mathematica Scandinavica* 3:155–169.
<http://www.mscaand.dk/article/view/10436/8457>
- [20] D. Gale and A. Mas-Colell. 1975. An equilibrium existence theorem for a general model without ordered preferences. *Journal of Mathematical Economics* 2(1):9–15.
DOI: 10.1016/0304-4068(75)90009-9
- [21] ———. 1979. Corrections to an equilibrium existence theorem for a general model without ordered preferences. *Journal of Mathematical Economics* 6(3):297–298.
DOI: 10.1016/0304-4068(79)90015-6
- [22] T. Ichiishi. 1981. A social coalitional equilibrium existence lemma. *Econometrica* 49(2):369–377.
<http://www.jstor.org/stable/1913316>
- [23] H. W. Kuhn. 1956. A note on ‘The law of supply and demand’. *Mathematica Scandinavica* 4:143–146.
<http://www.mscaand.dk/article/view/10463/8484>
- [24] ———. 1956. On a theorem of Wald. In H. W. Kuhn and A. W. Tucker, eds., *Linear Inequalities and Related Systems*, number 38 in Annals of Mathematics Studies, pages 265–274. Princeton: Princeton University Press.
- [25] M. J. P. Magill and M. Quinzii. 1996. *Theory of incomplete markets*, volume 1. Cambridge, Massachusetts: MIT Press.
- [26] A. Mas-Colell. 1974. An equilibrium existence theorem without complete or transitive preferences. *Journal of Mathematical Economics* 1(3):237–246.
DOI: 10.1016/0304-4068(74)90015-9
- [27] L. W. McKenzie. 1954. On equilibrium in Graham’s model of world trade and other competitive systems. *Econometrica* 22(2):147–161.
<http://www.jstor.org/stable/1907539>
- [28] ———. 1955. Competitive equilibrium with dependent consumer preferences. In H. A. Antosiewicz, ed., *Proceedings of the Second Symposium in Linear Programming*, pages 277–294, Washington, D.C. National Bureau of Standards and Directorate of Management Analysis, DCS/Comptroller, USAF.
- [29] ———. 1959. On the existence of general equilibrium for a competitive market. *Econometrica* 27:54–71.
<http://www.jstor.org/stable/1907777>
- [30] ———. 1961. On the existence of general equilibrium: Some corrections. *Econometrica* 29(2):247–248.
<http://www.jstor.org/stable/1909294>
- [31] ———. 1981. The classical theorem on existence of competitive equilibrium. *Econometrica* 49:819–841.
<http://www.jstor.org/stable/1912505>
- [32] ———. 2002. *Classical general equilibrium theory*. Cambridge Massachusetts: MIT Press.

- [33] J. C. Moore. 1975. The existence of “compensated equilibrium” and the structure of the Pareto efficiency frontier. *International Economic Review* 16(2):267–300.
<http://www.jstor.org/stable/2525812>
- [34] ———. 2007. *General equilibrium and welfare economics: An introduction*. Berlin, Heidelberg, & New York: Springer Science+Business Media.
- [35] T. Negishi. 1960. Welfare economics and existence of an equilibrium for a competitive economy. *Metroeconomica* 12(2–3):92–97. DOI: 10.1111/j.1467-999X.1960.tb00275.x
- [36] W. Neuefeind. 1980. Notes on existence of equilibrium proofs and the boundary behavior of supply. *Econometrica* 48(7):1831–1837. <http://www.jstor.org/stable/1911941>
- [37] H. Nikaidô. 1956. On the classical multilateral exchange problem. *Metroeconomica* 8(2):135–145. DOI: 10.1111/j.1467-999X.1956.tb00097.x
- [38] ———. 1957. A supplementary note to ‘On the classical multilateral exchange problem’. *Metroeconomica* 9(3):209–210. DOI: 10.1111/j.1467-999X.1957.tb00662.x
- [39] ———. 1968. *Convex structures and economic theory*. Mathematics in Science and Engineering. New York: Academic Press.
- [40] R. Radner. 1968. Competitive equilibrium under uncertainty. *Econometrica* 36(1):31–58.
<http://www.jstor.org/stable/1909602>
- [41] H. E. Scarf. 1973. *The computation of economic equilibria*. Number 24 in Cowles Commission for Research in Economics Monographs. New Haven, Connecticut: Yale University Press.
<http://cowles.econ.yale.edu/P/cm/m24/>
- [42] W. J. Shafer. 1976. Equilibrium in economies without ordered preferences or free disposal. *Journal of Mathematical Economics* 3(2):135–137. DOI: 10.1016/0304-4068(76)90022-7
- [43] W. J. Shafer and H. F. Sonnenschein. 1975. Equilibrium in abstract economics without ordered preferences. *Journal of Mathematical Economics* 2(3):345–348.
DOI: 10.1016/0304-4068(75)90002-6
- [44] ———. 1976. Equilibrium with externalities, commodity taxation, and lump sum transfers. *International Economic Review* 17(3):601–611.
<http://www.jstor.org/stable/2525791>
- [45] H. Sonnenschein. 1973. Do Walras’ identity and continuity characterize the class of community excess demand functions? *Journal of Economic Theory* 6(4):345–354.
DOI: 10.1016/0022-0531(73)90066-5
- [46] H. F. Sonnenschein. 1971. Demand theory without transitive preferences, with applications to the theory of competitive equilibrium. In J. S. Chipman, L. Hurwicz, M. K. Richter, and H. F. Sonnenschein, eds., *Preferences, Utility, and Demand: A Minnesota Symposium*, chapter 10, pages 215–223. New York: Harcourt, Brace, Jovanovich.

- [47] ——— . 1972. Market excess demand functions. *Econometrica* 40(3):549–563.
<http://www.jstor.org/stable/1913184>
- [48] ——— . 1977. Some recent results on the existence of equilibrium in finite purely competitive economies. In M. D. Intriligator, ed., *Frontiers of quantitative economics*, volume IIIA. Amsterdam: North Holland.
- [49] R. M. Starr. 1997. *General equilibrium theory: An introduction*. Cambridge, New York, and Melbourne: Cambridge University Press.
- [50] H. Uzawa. 1962. Walras' existence theorem and Brouwer's fixed point theorem. *Economic Studies Quarterly* 13.
- [51] J. von Neumann. 1935–1936. Über ein ökonomisches Gleichungssystem and und eine Verallgemeinerung des Brouwerschen Fixpunktsatzes. *Ergebnisse eines Mathematischen Kolloquiums* 8:73–83. Translation: “A Model of general economic equilibrium” *Review of Economic Studies*, 13(1945-1946) <http://www.jstor.org/stable/2296111>
- [52] ——— . 1945–46. A model of general economic equilibrium. *Review of Economic Studies* 13(1):1–9. <http://www.jstor.org/stable/2296111>
- [53] A. Wald. 1935. Über die eindeutige positive Lösbarkeit der neuen Produktionsgleichungen. *Ergebnisse eines Mathematischen Kolloquiums* 6:12–18. Translated as “On the Unique Non-Negative Solvability of the New Production Equations (Part 1),” in [5].
- [54] ——— . 1936. Über die Produktionsgleichungen der ökonomischen Wertlehre. *Ergebnisse eines Mathematischen Kolloquiums* 7:1–6. Translated as “On the Production Equations of Economic Value Theory (Part 2),” in [5].
- [55] ——— . 1936. Über einige Gleichungssysteme der mathematischen ökonomie. *Zeitschrift für Nationalökonomie* 7(5):637–670. Translated by Otto Eckstein as “On Some Systems of Equations of Mathematical Economics” [56].
- [56] ——— . 1951. On some systems of equations of mathematical economics. *Econometrica* 19(4):368–403. Translation by O. Eckstein of [55].
<http://www.jstor.org/stable/1907464>
- [57] L. Walras. 1874. *Eléments d'économie politique pure*. Lausanne: Corbaz.
- [58] W. R. Zame. 2007. Incentives, contracts, and markets: A general equilibrium theory of firms. *Econometrica* 75(5):1453–1500. DOI: [10.1111/j.1468-0262.2007.00799.x](https://doi.org/10.1111/j.1468-0262.2007.00799.x)